

16

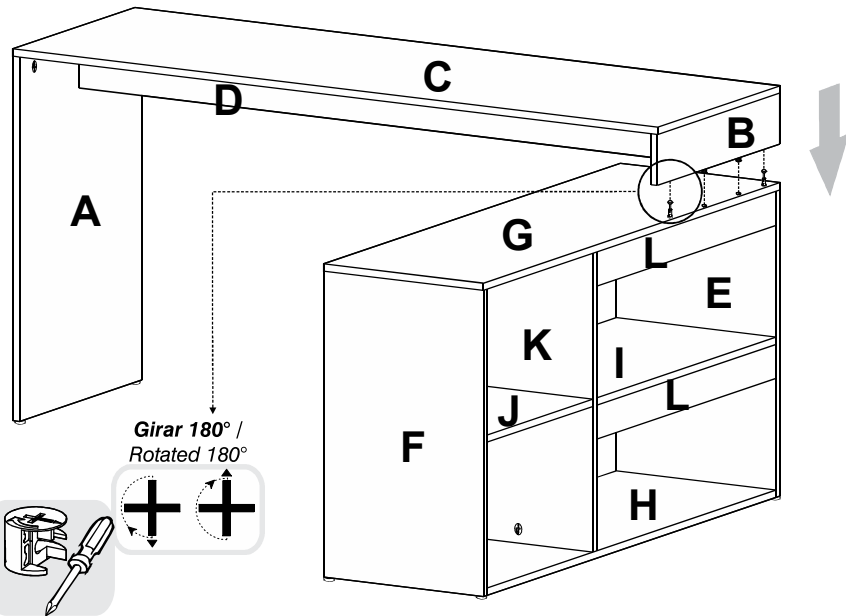

17

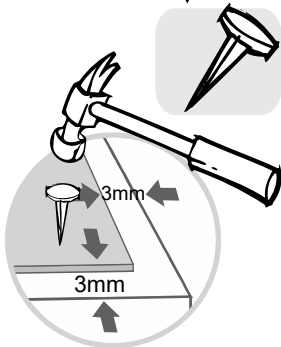
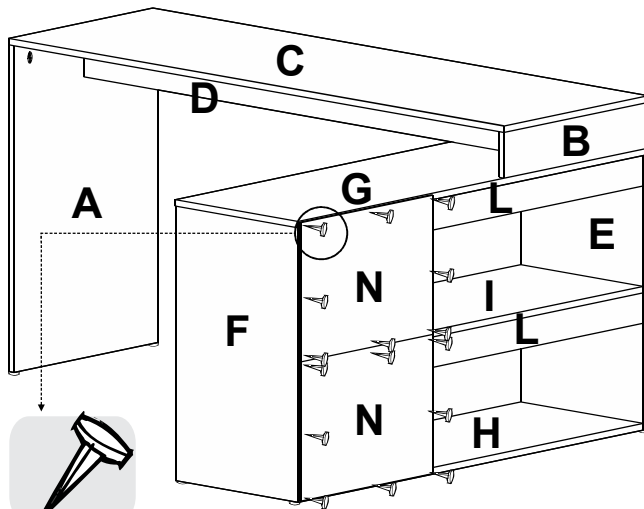

Al terminar de armar desprenda los adhesivos (en caso de que queden residuos de pegamento, limpie la superficie con alcohol) / When you finish off adhesive build (in case of residues of glue, wipe it with alcohol)

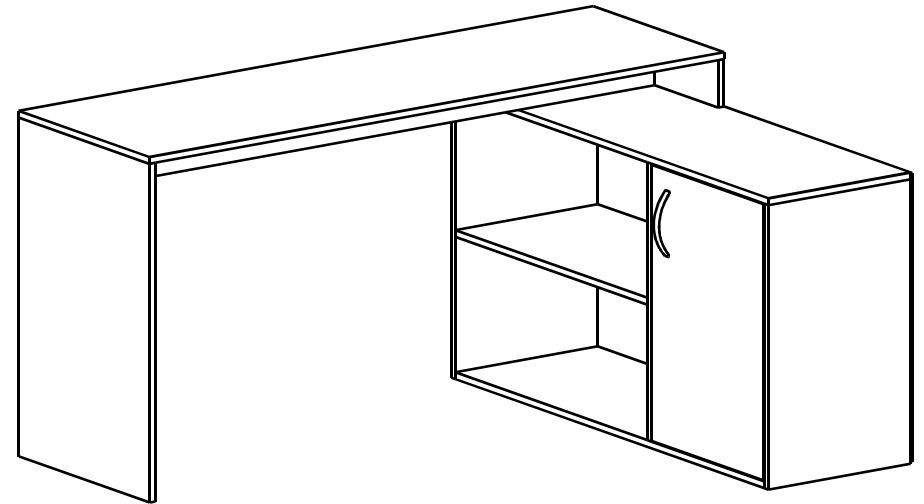

Alto/ Height: 76,5 cm / 30.11 in  
Ancho/ Width: 151,5 cm / 59.64 in  
Fondo/ Depth: 116,5 cm / 45.86 in

LOTE No: \_\_\_\_\_

By: **RTA**® TEL (572) 691 17 00  
m u e b l e s PBX (572) 695 91 81  
CALI - COLOMBIA  
[www.rta.com.co](http://www.rta.com.co)

**ESCRITORIO AXIS**  
/Axis Desk

## RECOMENDACIONES IMPORTANTES KEY RECOMMENDATIONS

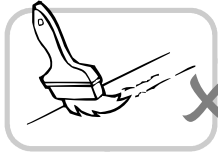

NO pinte el mueble /  
Do not paint the  
furniture.



NO mojar o ubicar  
a la intemperie /  
Do not expose to rain  
or direct sun.

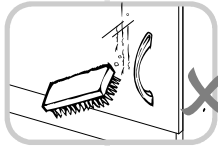
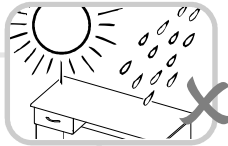

NO lavar las manijas o  
tiraderas con jabones o  
elementos abrasivos /  
Do not wash handles or  
dumps with soap or  
abrasives.

NO sobrecargue el mueble.  
no exceda el peso de 30 kilos  
para gabinetes de cocina /  
Do not overload the cabinet.  
Weight max. 66lbs  
for kitchen cabinets.

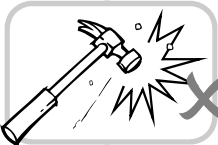

NO golpear ni martillar  
el mueble (hágalo sólo  
donde se indique) /  
Do not hit or hammer  
the furniture (just do it  
where is indicated).

NO permita que los niños  
manipulen el mueble, puede  
voltearse y lastimarlos /  
Do not allow children to  
handle the cabinets or  
drawers, they could get hurt.

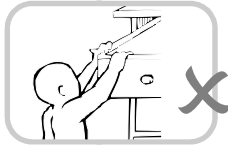

SIEMPRE levante el  
mueble entre dos  
personas, NO lo arrastre /  
Do not drag the furniture.  
Lift it between two people.

Limpie con paño seco,  
/ Clean with a dry cloth.



## HERRAJES BÁSICOS PARA MUEBLES RTA BASIC HARDWARE FOR RTA FURNITURE

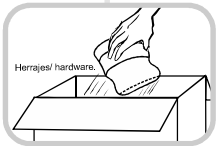

1. Abrir la caja del mueble  
y buscar la bolsa con los  
herrajes / Open the box  
and look for the hardware  
bag.

3. Separe los herrajes para  
facilitar su identificación  
durante el armado /  
Separate hardware for easy  
identification during  
assembly.

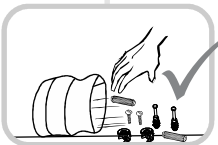
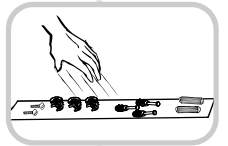

2. Abrir el paquete y  
comprobar que el  
contenido de las piezas es  
correcto / Open the  
package and verify that  
the content of the pieces  
is correct.

4. Arme el mueble en un lugar  
limpio y en una superficie  
plana / RTA furniture  
must be assembled  
in a clean place and on  
a flat surface.

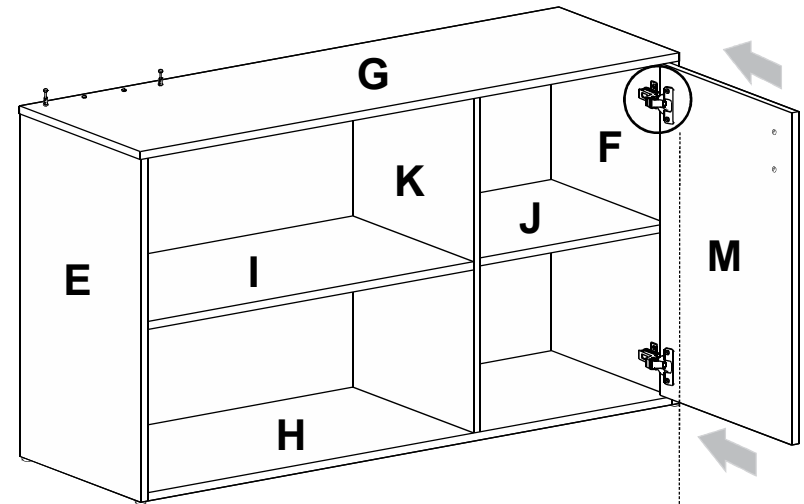
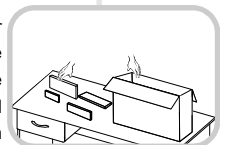

## INSTALACIÓN DE BISAGRAS / FULL OVERLAY HINGE INSTALLATION

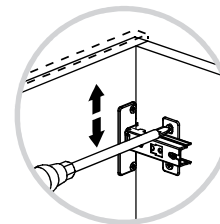

AJUSTE DE ALTURA  
HEIGHT ADJUSTMENT

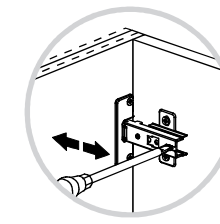

AJUSTE DE PROFUNDIDAD  
DEPTH ADJUSTMENT

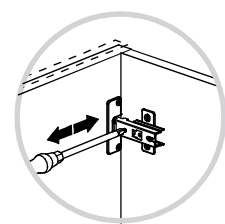

AJUSTE LATERAL  
SIDE ADJUSTMENT

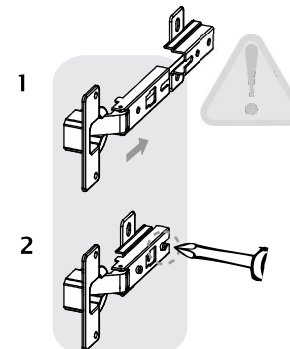

Al finalizar el ajuste de los  
conectores, proceda a  
poner las tapas adhesivas/  
When you finish the adjustment  
of the connectors, proceed to  
put the cover tapes

13

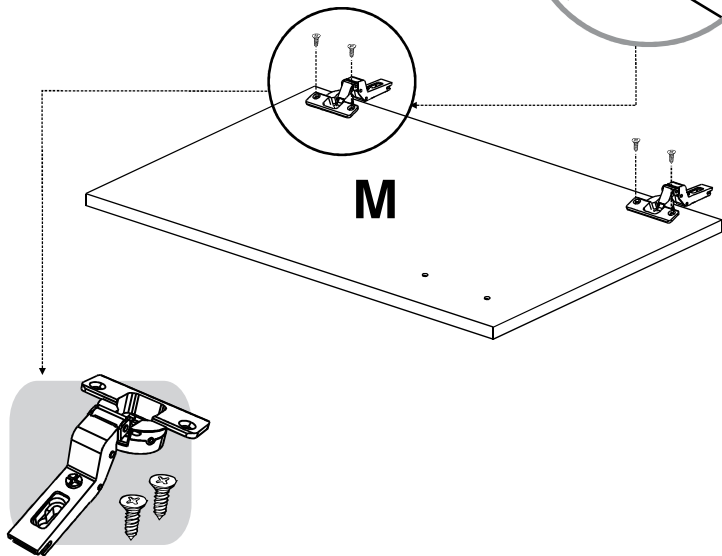
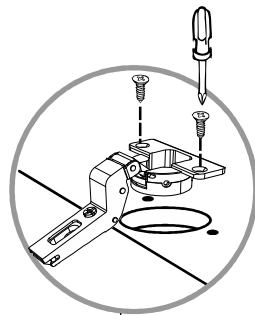

14

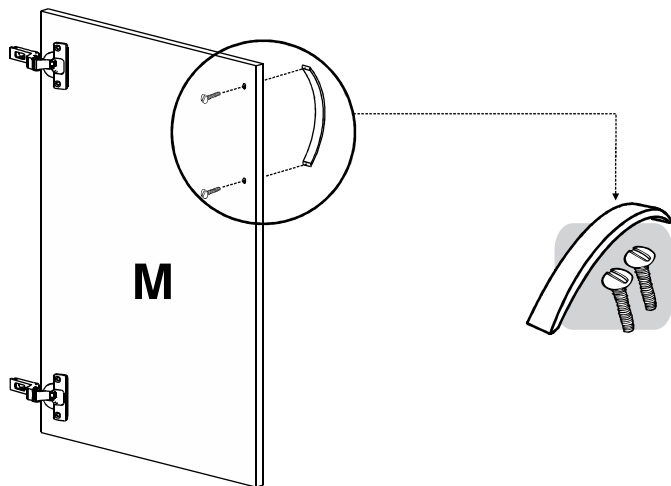

## RECOMENDACIONES DE ENSAMBLE / ASSEMBLY RECOMMENDATIONS

El buen funcionamiento del mueble depende de un adecuado ensamblaje  
An excellent furniture's performance relies on a solid and a suitable assembly.

### MINIFIX / CONNECTOR - DOWELS

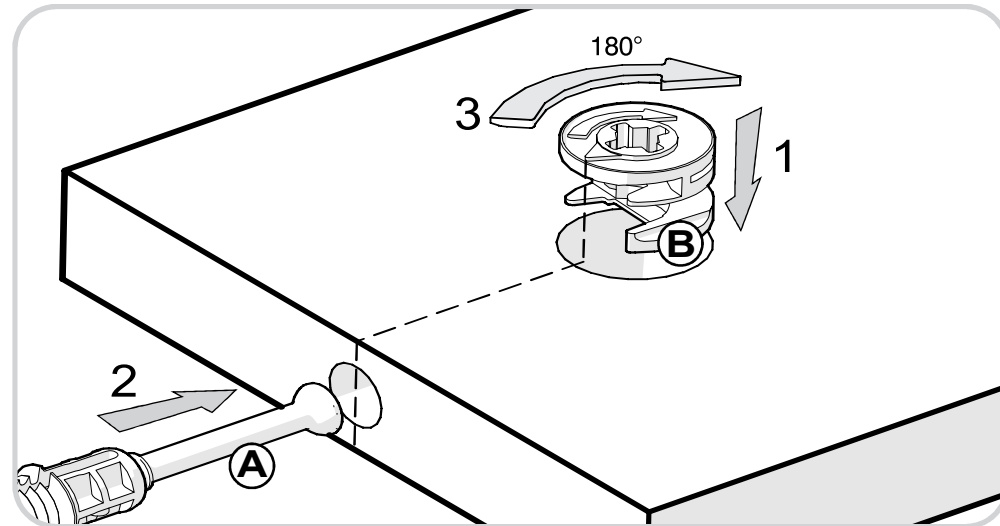

Sistema de unión compuesto por un perno (A) y una caja minifix (B).

(1) Se inserta la caja minifix dentro de la perforación ubicada en la cara de la pieza, la flecha debe apuntar siempre a la dirección de la perforación por donde entrará el perno.

(2) Se debe insertar el perno por su parte plástica en las perforaciones que se indiquen, luego se inserta la punta metálica en la perforación para que su cabeza quede al interior de la caja minifix.

(3) Girar la caja minifix 180° para apretar las dos piezas.

It's a fitting system made of a spreading bolt (A) and a minifix cam (B).

(1) Insert the minifix cam in the hole placed in the face of the panel with the arrow pointing towards the hole where the bolt will fit.

(2) Insert the bolt with its plastic base in the shown holes, then insert the metallic bolt head in the holes so it fits inside the minifix cam.

(3) Tight the panels by turning the minifix cam 180°.

### TARUGOS O TAQUETES / FLUTED DOWEL PIN

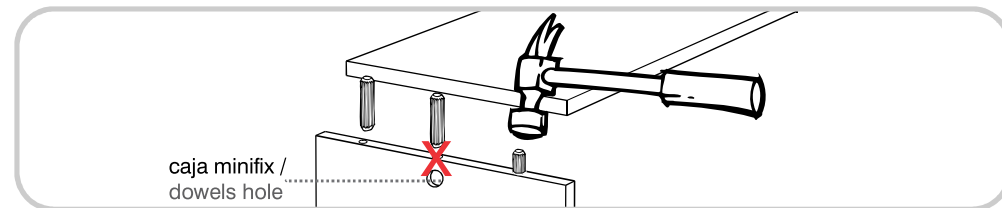

Es un pedazo de madera corto y grueso, de aproximadamente 3 a 10 cm de largo, que sirve para amarrar el mueble y darle resistencia.

It's a short and thick piece of wood, 1,18 to 3,9 inches approximately, which is used to tie the cabinet and give it resistance.

## RECOMENDACIONES IMPORTANTES / KEY RECOMMENDATIONS

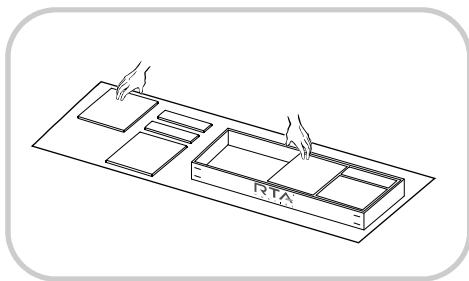

Se recomienda armar el mueble sobre la caja o una superficie lisa para no rayarlo. It is recommended to assemble the product on the box or on a flat surface to not scratch it.

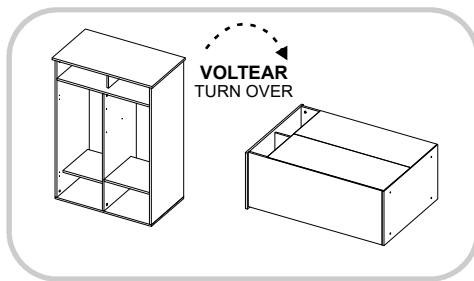

Voltear el mueble cuidadosamente para ensamblar los fondos. Carefully turn over the cabinet to assemble the back panels.

## PESO MAX. SUGERIDO EN MUEBLE (Kg) / MAX SUGGESTED LOAD (Kg)

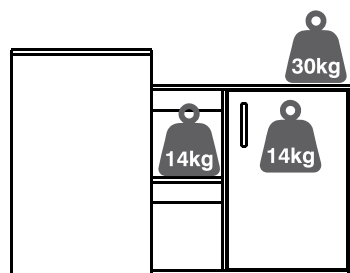
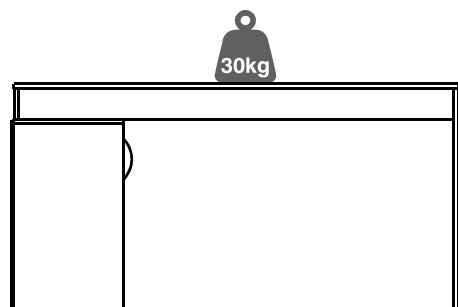

**NOTA:** La resistencia a las cargas puede variar dependiendo si es una carga distribuida o una carga puntual, las gráficas corresponden a cargas puntuales, NO exceder los pesos sugeridos / **NOTE:** The load capacity depends if it is a *point load* or if it is an *uniform distributed load*, do not exceed the suggested loads.

11

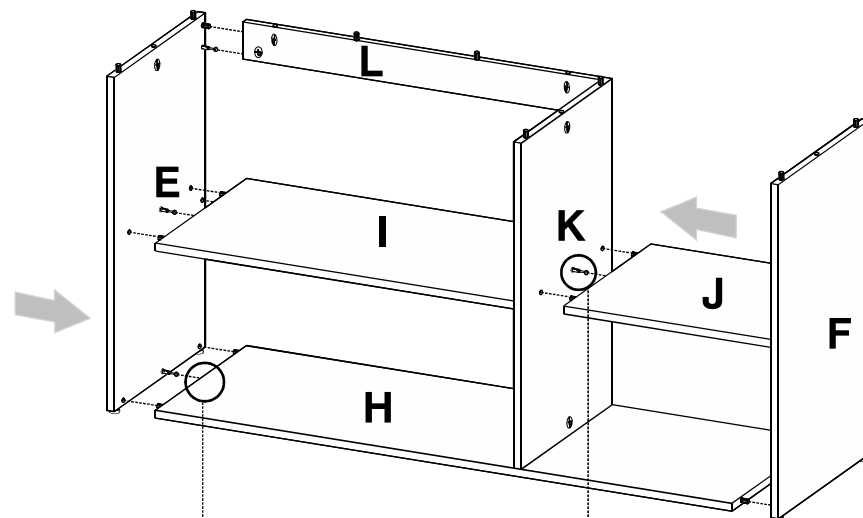

Girar 180° / Rotate 180°

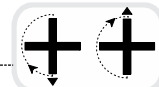

No olvide apretar todos los conectores / Do not forget to tighten every connector

12

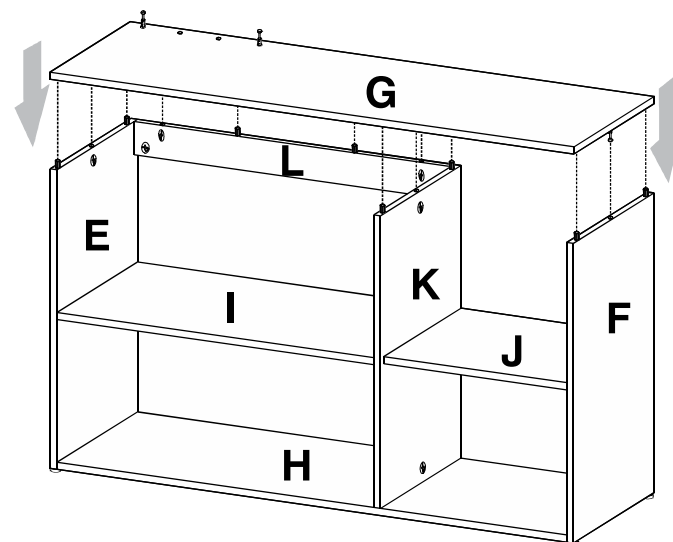

9

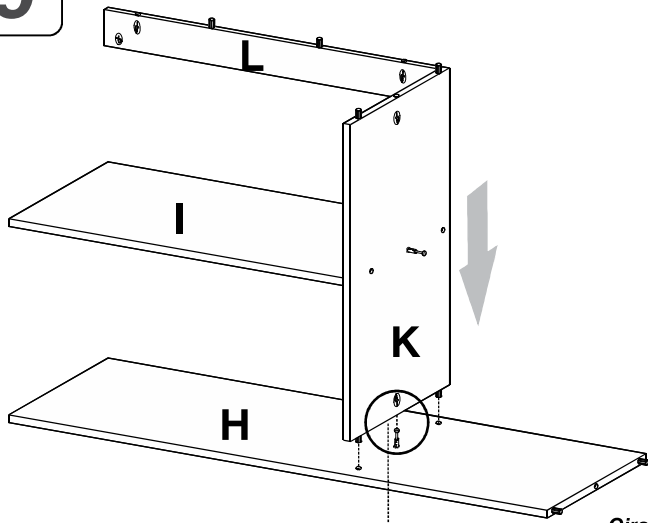

Gírar 180° /  
Rotate 180°

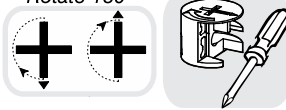

No olvide apretar  
todos los conectores /  
Do not forget to  
tighten every connector

10

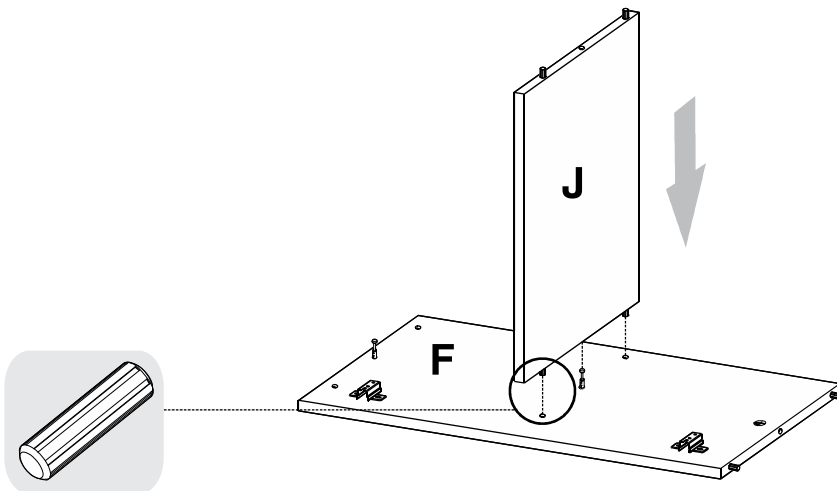

## HERRAJES PARA ARMADO ASSEMBLY HARDWARE

x27

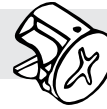

Minifix/  
Minifix Cams

x27

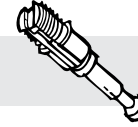

Perno minifix/  
Dowels

x42



Tarugo/  
Wooden pin

x30



Tapa Minifix/  
Cover Caps

x16



Puntillas/  
Panel Pin

x8



Tornillo lámina  
6 X 9/16"/  
Sheet Metal Screw

x1



Manija/  
Handle

x2



Tornillo Manija/  
Handle Screw

x6



Deslizador/  
Plastic Glide

x2

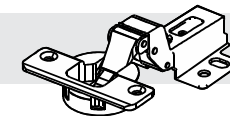

Bisagra Interior  
(Incluye tornillos)  
Inset Hinge  
(Screws included)



TENER PRECAUCIÓN AL ABRIR LA BOLSA DE HERRAJES PARA NO EXTRAVIAR NINGUNO. COMPRUEBE QUE EL CONTENIDO DE LAS PIEZAS SEA EL CORRECTO. EN CASO QUE FALTE ALGUNA PIEZA O ESTE DEFECTUOSA DEVUELVA LAS PIEZAS AL ALMACÉN CON SU FACTURA PARA EFECTUAR EL CAMBIO DE LAS PIEZAS Y/O LOS HERRAJES LO MÁS PRONTO POSIBLE. / PLEASE BE CAUTIOUS WHEN OPENING THE HARDWARE BAG TO NOT LOSE ANY. CHECK THE CONTENTS OF THE PARTS ARE CORRECT. IF ANY PART IS MISSING OR DEFECTIVE PLEASE RETURN THE PARTS TO THE STORE WITH THE PRODUCT INVOICE ATTACHED TO MAKE EFFECTIVE THE REPLACEMENT OF THE DEFECTIVE PIECES OR WARDWARE AS SOON AS POSSIBLE.

# PIEZAS DE ARMADO ASSEMBLY PARTS

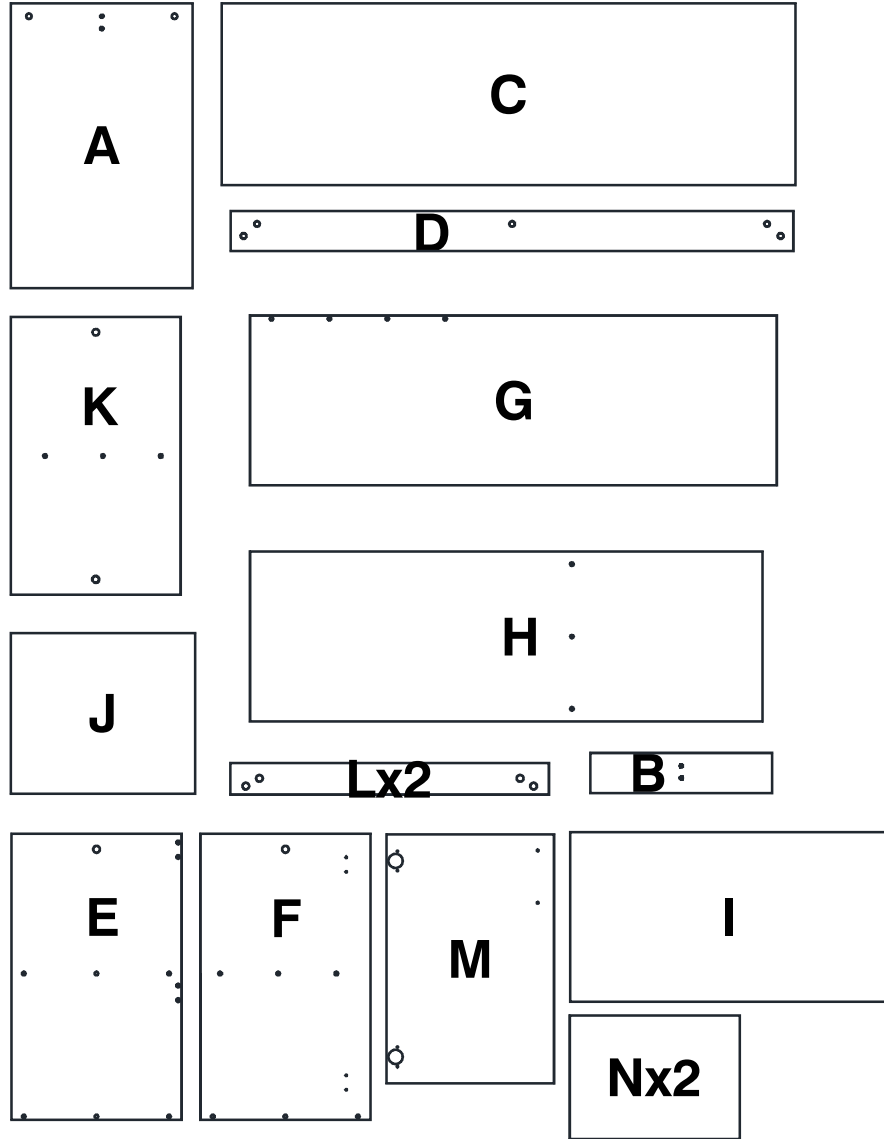

ANTES DE EMPEZAR A ARMAR EL MUEBLE LEA DETENIDAMENTE LAS INSTRUCCIONES. SE RECOMIENDA ARMAR EL MUEBLE SOBRE LA CAJA O SOBRE UNA SUPERFICIE LISA Y CUBIERTA, PARA NO RAYARLO / BEFORE STARTING TO ASSEMBLE THE FURNITURE, CAREFULLY READ THE INSTRUCTIONS. IT IS RECOMMENDED TO ASSEMBLE THE FURNITURE ON THE BOX OR ON A FLAT AND COVERED SURFACE IN ORDER TO NOT SCRATCH THE PRODUCT.

7

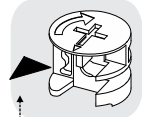
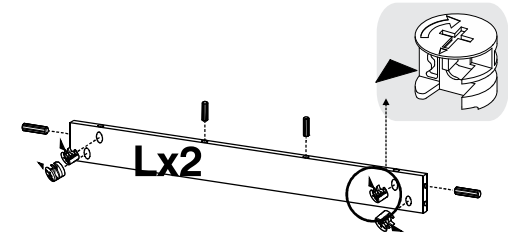
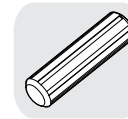
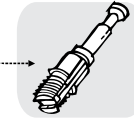
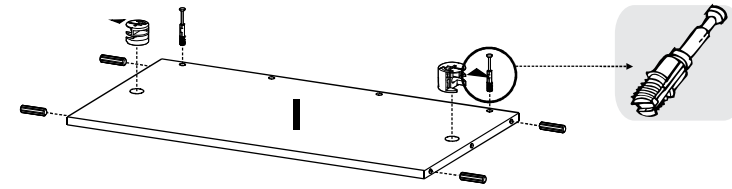

8

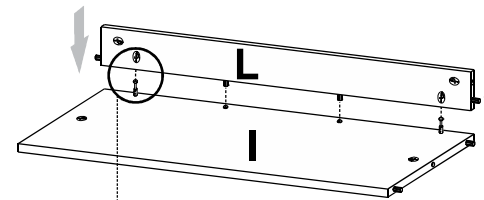

Girar 180° /  
Rotate 180°

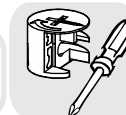

No olvide apretar todos los conectores /  
Do not forget to tighten every connector

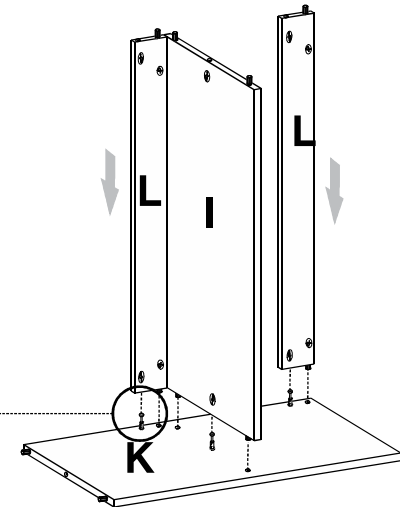

5

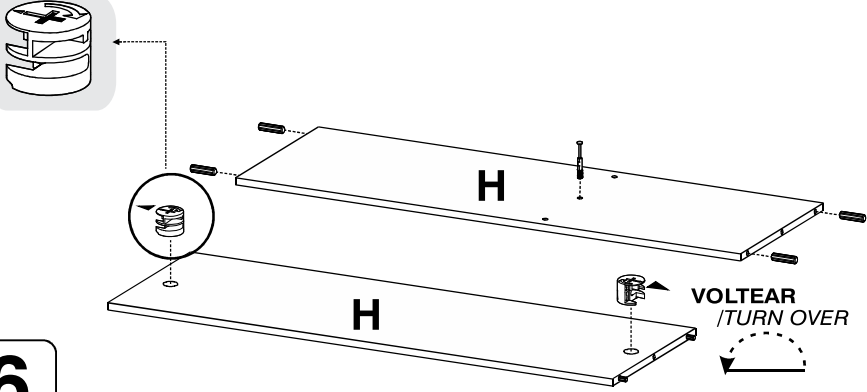
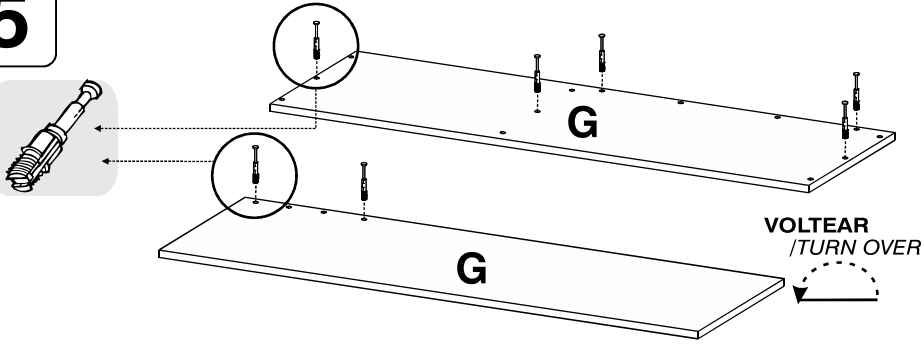

6

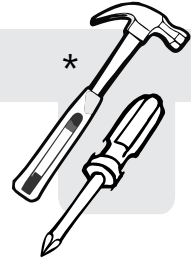
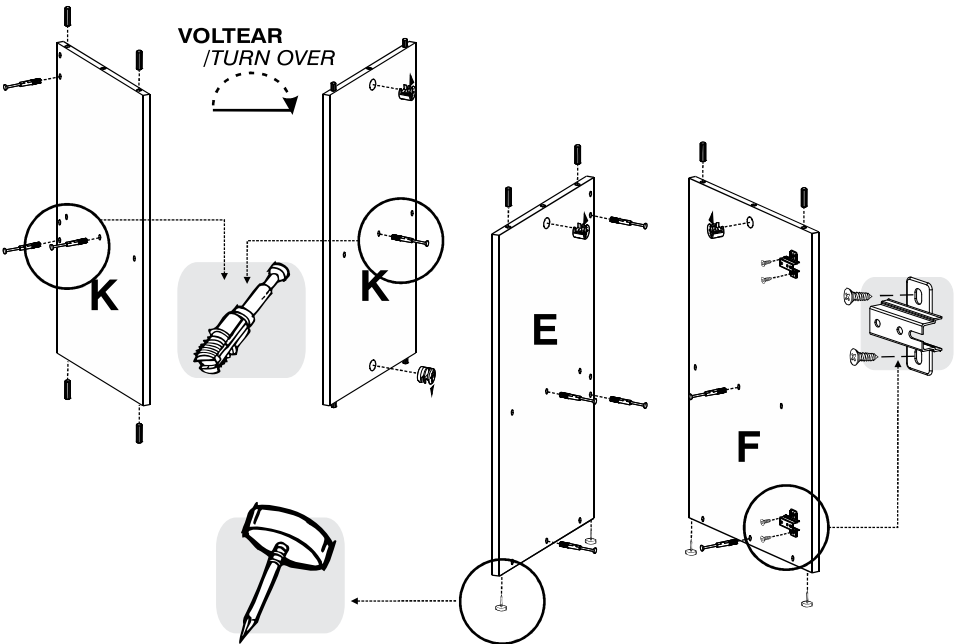

\*Herramientas NO incluidas / Tools not included

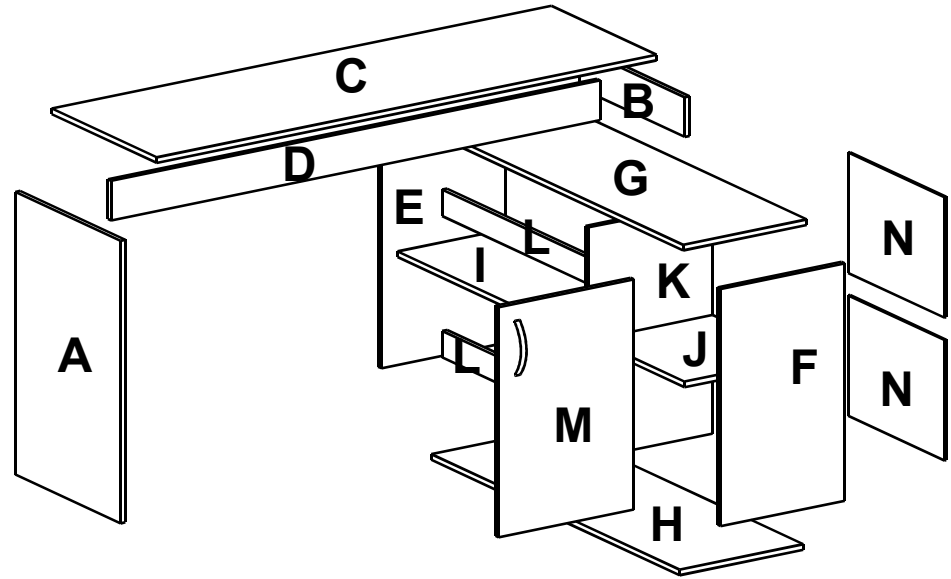

**1**

SE RECOMIENDA ARMAR EL MUEBLE ENTRE DOS PERSONAS /  
IT IS RECOMMENDED TO ASSEMBLE THE PRODUCT BETWEEN TWO PEOPLE

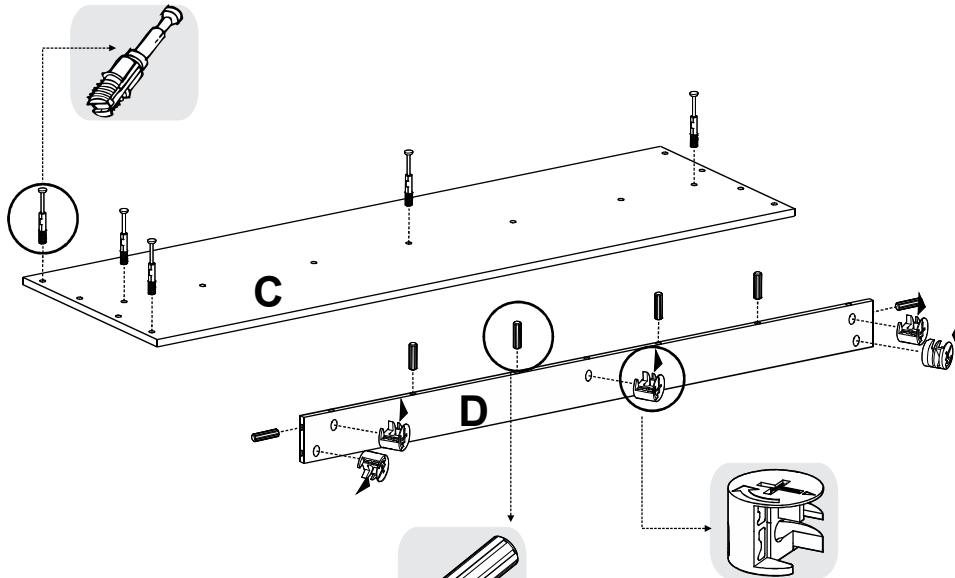
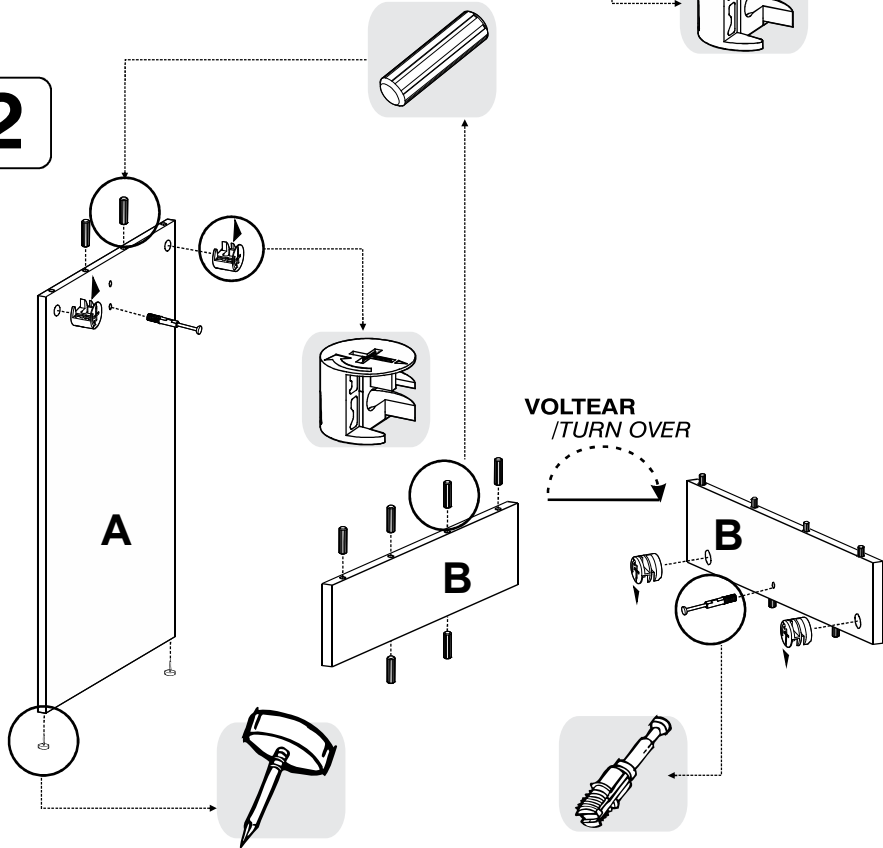
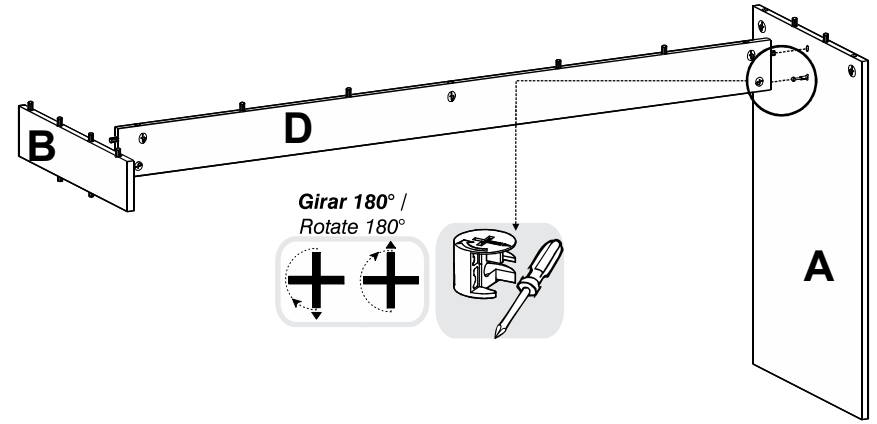
**2****3**

No olvide apretar  
todos los conectores /  
Do not forget to  
tighten every connector

**4**